

Drehschieber-Verdichter
Rotary vane compressors
Compresseurs à palettes
Compressori a palette

trockenlaufend, luftgekühlt
 oil-free, air-cooled
 fonctionnant à sec, refroidies par air
 funzionanti a secco, raffreddate ad aria

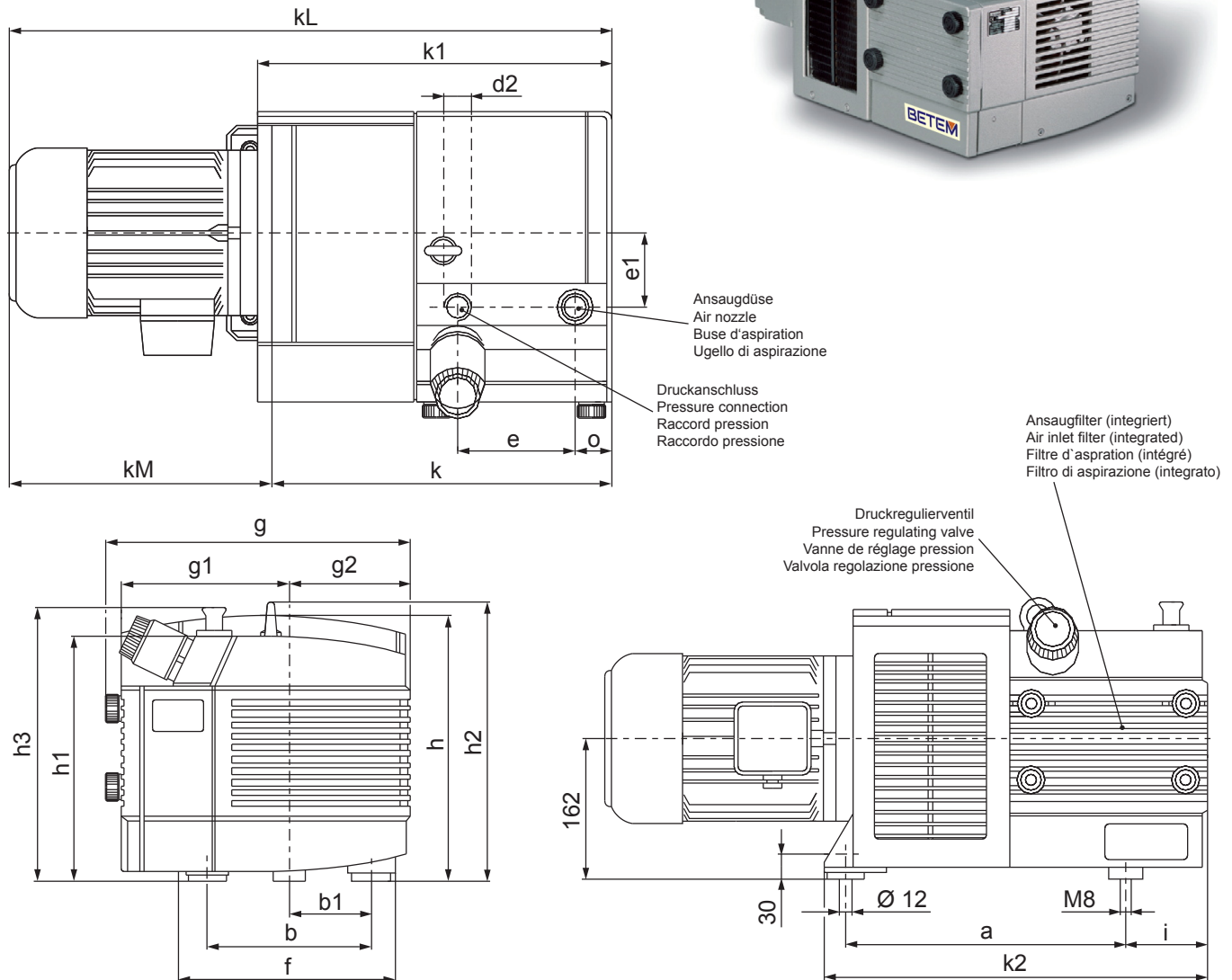

Typ Type Type Tipo	Blasluftmenge Blast air rate Débit d'air soufflé Volume d'aria soffiata		Überdruck Pressure Pression Pressione	Installierte Motorleistung Motor capacity installed Puissance du moteur installé Potenza del motore installato		Drehzahl [U/min] Speed [RPM] Vitesse de rotation [T/min] Velocità di rotazione [G/min]		Schallpegel Noise level Niveau sonore Livello rumorosità (DIN 45635-1) [dB (A)]		Gewicht Weight Poids Peso									
	[m³/h max.]			3~ [kW]															
	50 Hz	60 Hz		50 Hz	60 Hz	50 Hz	60 Hz	50 Hz	60 Hz										
BTF 60	60	72	1,5	3.0	3.6	1420	1700	72	72	69,0									
BTF 80	80	96	1,5	4.0	4.8	1420	1700	74	74	77,0									
BTF 100	100	120	1,5	5.5	6.6	1420	1700	76	76	127									
BTF 140	140	168	1,5	7.5	9.0	1420	1700	82	82	146									
Spannung / Voltage Voltage / Voltaggio		3~ (3,0 – 4,8 kW) = 230 / 400 V ±10% 50 Hz + 230 / 400 V ±10% 60 Hz 3~ (5,5 – 9,0 kW) = 400 / 690 V ±10% 50 Hz + 400 / 690 V ±10% 60 Hz																	
	a	b	b1	d2	e	f	g	g1	g2	h	h1	h2	h3	i	k	k1	k2	kM	kL
BTF 60	327	190	95	G 1	138	250	353	195	141	289	262	328	312	96	397	415	448	306	700
BTF 80	327	190	95	G 1	138	250	353	195	141	289	262	328	312	96	397	415	448	306	703
BTF 100	421	245	122.5	G1½	190	295	470	223	230	297	275	336	330	140	501	539	563	370	770
BTF 140	411	245	122.5	G1½	190	295	470	223	230	297	275	336	330	140	501	639	563	408	770

Maßangaben in mm / Measures in mm / Mesures en mm / Misure in mm

Änderungen vorbehalten / Right of modification reserved / Sous réserve des modifications / Sotto riserva di modificazioni

m³/h

Blasluftmenge • Blast air rate • Débit d'air soufflé • Volume d'aria soffiata

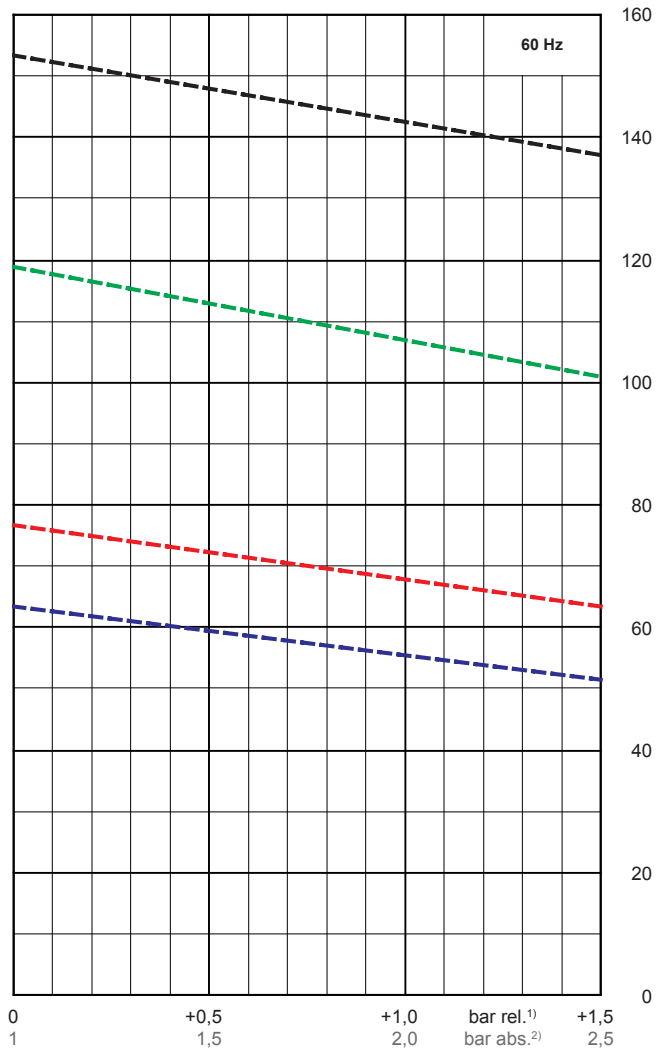
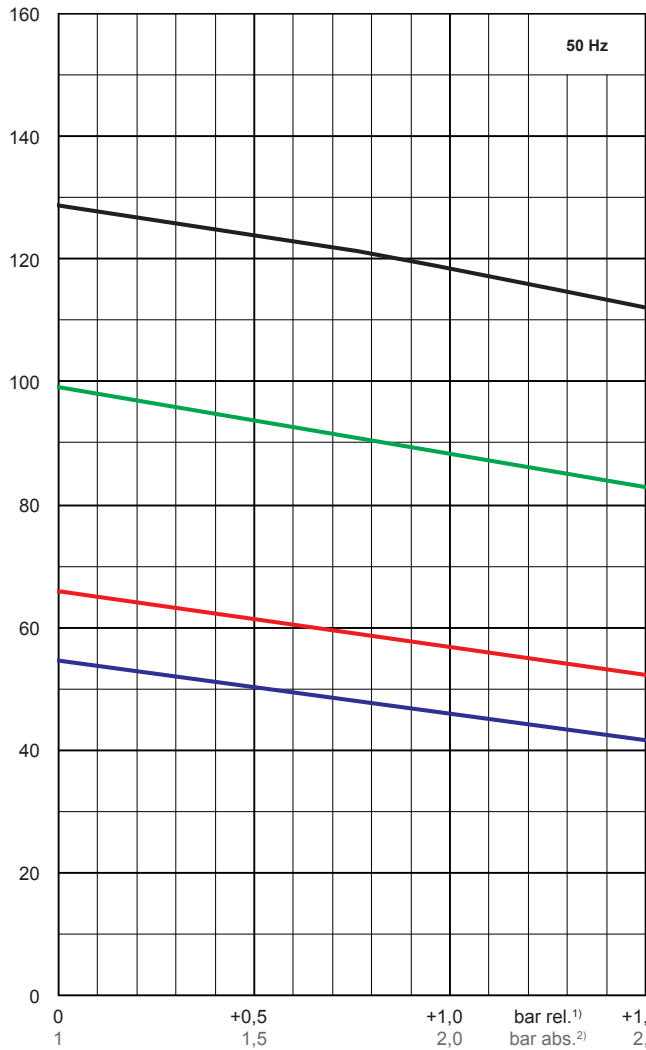

°C

Max. Drucklufttemperatur • Max. temperature compressed air
Max. température air comprimé • Mas. temperatura aria compressa

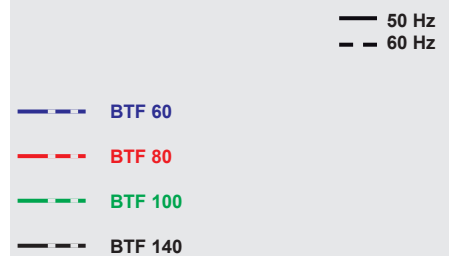
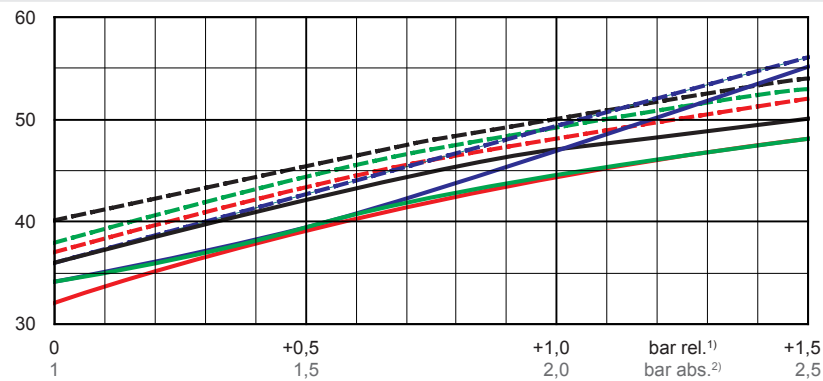

kW

Max. Wellenleistung • Max. motor shaft capacity
Max. puissance du moteur axe • Mas. potenza del motore albero

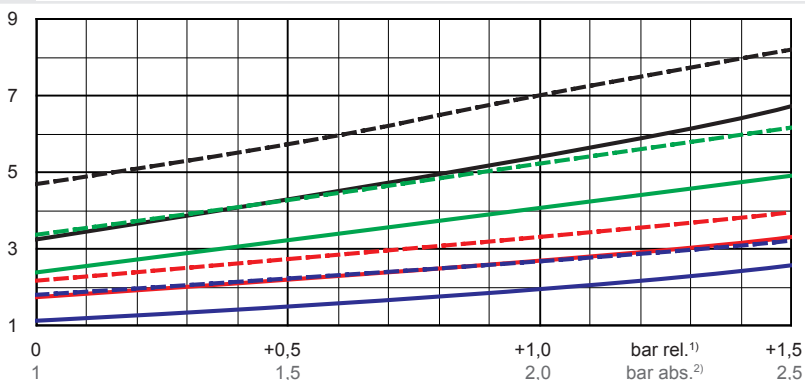

1) bar relativ • bar relative • bar relatif • bar relativo
2) bar absolut • bar absolute • bar assoluto • bar assoluto

Bezugsdaten (Atmosphäre) • Reference (atmosphere) • Référence (atmosphère) • Riferimento (atmosfera) : 1000 mbar, 20°C

Mögliche Abweichung • Allowable tolerance • Variation possible • Variazione possibile : ±5 %